

SNQ-60x0-320 Series Data Center Switch Hardware Installation Guide

FCC Warning

NOTE: This equipment has been tested and found to comply with the limits for a class A digital device, pursuant to Part 15 of the FCC rules. These limits are designed to provide reasonable protection against harmful interference when the equipment is operated in a commercial environment. This equipment uses, generates, and can radiate radio frequency energy and if not installed in accordance with the operator's manual, may cause harmful interference to radio communications. Operation of this equipment in a residential area is likely to cause interference in which case the user will be required to correct the interference at his/her own expense.

WARNING: Changes or modifications made to this device which are not expressly approved by the party responsible for compliance could void the user's authority to operate the equipment.

CE Mark Warning

This is a Class A product. In a domestic environment, this product may cause radio interference in which case the user may be required to take adequate measures.

BSMI Notice

警告使用者: 此為甲類資訊技術設備，於居住的環境中使用時，可能會造成射頻擾動，在此種情況下，使用者會被要求採取某些適當的對策。

警告

此为 A 级产品，在生活环境中，该产品可能会造成无线电干扰。在这种情况下，可能需要用户对其干扰采取切实可行的措施。

Safety Compliance**Warning: Class 1M Laser Product (Laser Radiation):.**

- **EN:** Class 1M laser radiation when open. Do not view directly with optical instruments
- **FR:** Radiation laser de classe 1M en cas d'ouverture. Ne pas observer directement avec des instruments optiques.

GBIC, SFP (Mini-GBIC), QSFP+, XENPAK, and XFP Regulatory Compliance

- Class 1M.
- EN60825-1:2007 2nd Edition or later, European standard.
- FCC 21 CFR Chapter 1, Subchapter J in accordance with FDA and CDRH requirements.
- Application of CE Mark in accordance with 2004/108/EEC EMC Directive and the 2006/95/EC Low Voltage Directives.
- UL and/or CSA registered component for North America.
- 47 CFR Part 15, Class A when installed into Alpha products.

Table of Contents

| | |
|---|-----------|
| Intended Readers | 1 |
| Audience | 1 |
| Other Documentation..... | 1 |
| Typographical Conventions..... | 1 |
| Style Format Conventions..... | 1 |
| Icon Conventions..... | 1 |
| Introduction | 2 |
| Switch Description | 2 |
| Package Contents..... | 2 |
| Software Features..... | 2 |
| Switch Components | 3 |
| Front Panel Components..... | 3 |
| LED Indicators | 3 |
| Back Panel Components..... | 4 |
| Power Supply Modules..... | 5 |
| Fan Modules | 6 |
| Side Panel Components..... | 6 |
| Hardware Installation | 8 |
| Installation Guidelines | 8 |
| Installation using the Rubber Feet..... | 8 |
| Installation into a Rack | 8 |
| Installing Transceivers into the Transceiver Ports..... | 12 |
| Installing Power Modules into the Power Module Slots..... | 14 |
| Installing an AC Power Supply Module..... | 14 |
| Installing a DC Power Supply Module | 15 |
| Installing Fan Modules into the Fan Module Slot | 16 |
| Technical Specifications | 18 |
| Product Specifications | 18 |
| Regulatory Standards Compliance | 19 |
| Safety Instructions | 21 |
| Safety Precautions..... | 21 |
| Electrical Safety Precautions | 21 |
| Rack-mount Safety Precautions..... | 21 |
| Ordering Information | 23 |
| Chassis | 23 |
| Power Supply Modules | 23 |
| Fan Modules..... | 23 |

Intended Readers

Audience

This guide is intended for network administrators and other IT networking professionals responsible for installing and maintaining switches in this series. When universal installation is applicable, all the switches in this series will simply be referred to as the *switch* within this guide. This guide is written in a way that assumes that users already have the experience and knowledge of Ethernet and modern networking principles for Local Area Networks.

Other Documentation

The documents below are a further source of information in regards to configuring and troubleshooting the switch. All the documents are available from the product website. Other documents related to this switch are:

- *SNQ-60x0-320F Series Datasheet*
- *SNQ-60x0-320F Series Quick Installation Guide*.

Typographical Conventions

Throughout this document certain typographical conventions will be used to either emphasize information or represent the features that this switch has to offer in a way that is understandable and useful to the reader.

Style Format Conventions

The following style format conventions will be used in this document.

| Convention | Description |
|----------------------|---|
| Boldface Font | This convention is used to place emphasis on a keyword with a sentence used in this document. |
| <i>Italic Font</i> | This convention is used to indicate a variable. An example of a variable is file names. |

Icon Conventions

The following icon conventions will be used in this document.



Note: The note icon convention is used to highlight an important topic that could be useful to the reader.



Warning: The warning icon convention is used to warn the reader of potential hazards that might result in the loss of data, potential damage to hardware or property, personal injury, or fatality. This warning will also inform the reader how to avoid the problem.

Introduction

Switch Description

The SNQ-60x0-320F Series Data Center, Top-of-Rack (ToR) switches, with a total combined bandwidth of 2,560 Gbps, feature 32 ports of 40 Gbps Ethernet wire-speeds or up to 104 ports of 10 Gbps Ethernet wire-speeds. The Layer 3 capable, bare metal system also provides an RJ-45 and a Micro-USB console port and an Out-Of-Band (OOB) management port. Administrators can access the Command Line Interface (CLI) through either the RJ-45 console port or the Micro-USB console port. When both console ports are active, the Micro-USB console port will be given priority.

The SNQ-60x0-320F Series features two switches in the series distinguished only by the CPU used. The **SNQ-6070-320F** uses the Freescale CPU and the **SNQ-60A0-320F** uses the Intel CPU.

Package Contents

After purchasing any of the switches in this series, the following items will be included in the package:

- One SNQ-60x0-320F Series Switch (This includes 1 power supply module and 4 fan modules).
- One Quick Installation Guide.
- One AC power cord.
- One RS-232-to-RJ45 console cable.
- One Micro-USB-to-USB console cable.
- One pair of frontal rack-mount brackets.
- One pair of rack-mount slider brackets.
- Four rubber feet with adhesive patches.
- Eight Phillips-head frontal rack-mount bracket screws.
- One warranty card.



Note: If any of the above mention items was not found inside the package contents of this switch or are damaged in any way, contact your reseller immediately.

Software Features

Switches within this series are known as bare metal devices. This means that this switch does not have any software pre-loaded on it.

Switch Components

In this chapter we'll discuss the physical components that can be found on the front, side, and back panels of switches in this series.

Front Panel Components

The front panel of switches in this series features the following components:

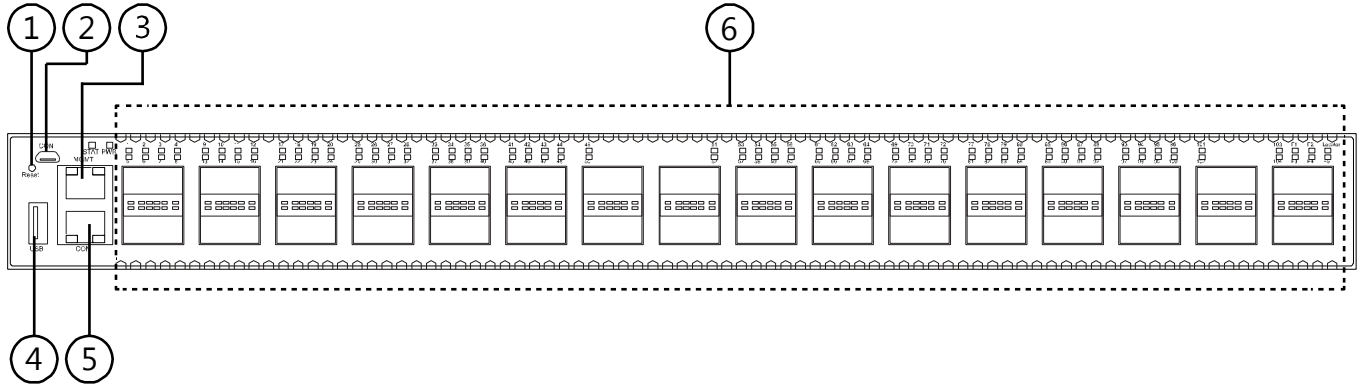

Figure 4-1 Front Panel of SNQ-60x0-320F Series Switch (Ports)

The following table lists the physical ports and buttons available on the front panel of the switch.

| Number | Description |
|--------|--|
| 1 | One reset button that can be used to perform a factory reset of the software loaded on this switch. |
| 2 | One Out-Of-Band, micro-USB (type-B) console port. When both console ports are active, this port will have the priority. |
| 3 | One Out-Of-Band, RJ45 management port. This port operates at 10/100/1000 Mbps wire-speeds. |
| 4 | One USB 2.0 (type-A) storage port. |
| 5 | One Out-Of-Band, RJ45 console port |
| 6 | Thirty-two Quad Small Form-factor Pluggable (QSFP+) ports. <ul style="list-style-type: none"> Ports 1 to 48 and 53 to 100 operate at 10/40 Gbps Ethernet wire-speeds. Ports 49 to 52 and 101 to 104 operate at 40 Gbps Ethernet wire-speeds. |

LED Indicators

The front panel of switches in this series features the following LED indicators:

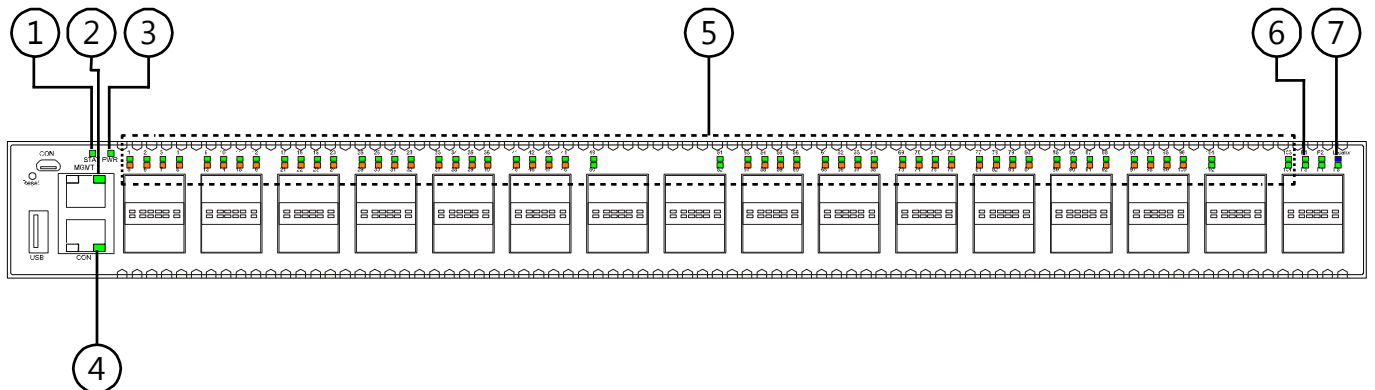

Figure 4-2 Front Panel of SNQ-60x0-320F Series Switch (LED Indicators)

The following table lists the LED indicators available on the front panel of the switch.

| Number | LED Indicator | Color | Behavior | Description |
|--------|---|-------|-------------|---|
| 1 | STAT | Green | Solid Light | POST passed. Normal operation. |
| | | | Blinking | POST in progress. |
| | | | Off | Power off. |
| | | Amber | Blinking | POST, power supply, or fan module failed. System too hot. |
| 2 | MGMT | Green | Solid Light | Connection is active. |
| | | | Blinking | Packets transmitted and received. |
| | | | Off | No connection detected. Port is disabled. |
| 3 | PWR | Green | Solid Light | Power on |
| | | | Off | Power off. No power cable attached. |
| | | Amber | Blinking | Power supply failure. Voltage, Current, or Temperature is too high. |
| 4 | Console | Green | Solid Light | Console is on. |
| | | | Off | Console is off. |
| 5 | Link/Activity/Speed (Ports 1-48, 53-100) | Green | Solid Light | Secure 40 Gbps connection is active. |
| | | | Blinking | Packets transmitted and received. |
| | | | Off | No active connection or port disabled. |
| | | Amber | Solid Light | Secure 10 Gbps connection is active. |
| | | | Blinking | Packets transmitted and received. |
| | | | Off | No active connection or port disabled. |
| | Link/Activity/Speed (Ports 49-52, 101-104) | Green | Solid Light | Secure 40 Gbps connection is active. |
| | | | Blinking | Packets transmitted and received. |
| | | | Off | No active connection or port disabled. |
| 6 | FAN 1, 2, 3, 4, 5 | Green | Solid Light | Diagnostics passed. Normal operation. |
| | | | Off | Not receiving power. |
| | | Amber | Blinking | Fan failure. |
| 7 | Locator | Blue | Blinking | Locator function is enabled |
| | | | Off | Locator function is disabled. |



Note: For more information about supported QSFP+ transceivers and transceiver installation, refer to the **Installing Transceivers into the Transceiver Ports** section later on.

Back Panel Components

The back panel of switches in this series features the following components:

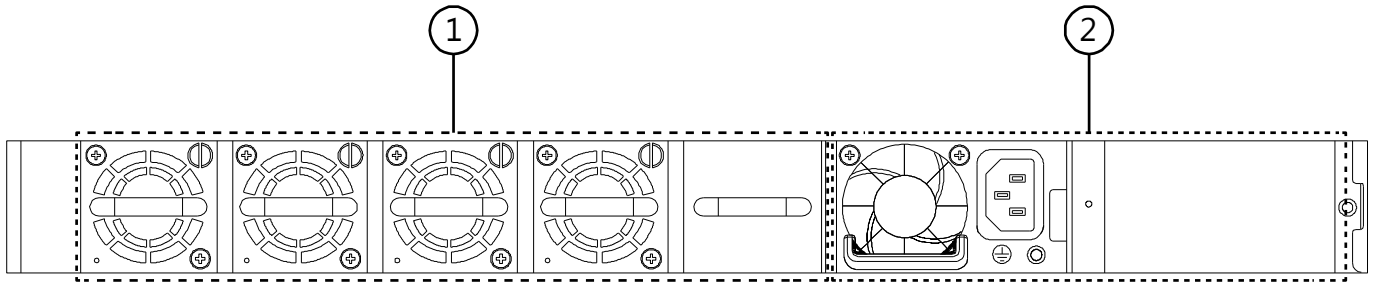

Figure 4-3 Back Panel of SNQ-60x0-320F Series Switch with AC Power Supply Module

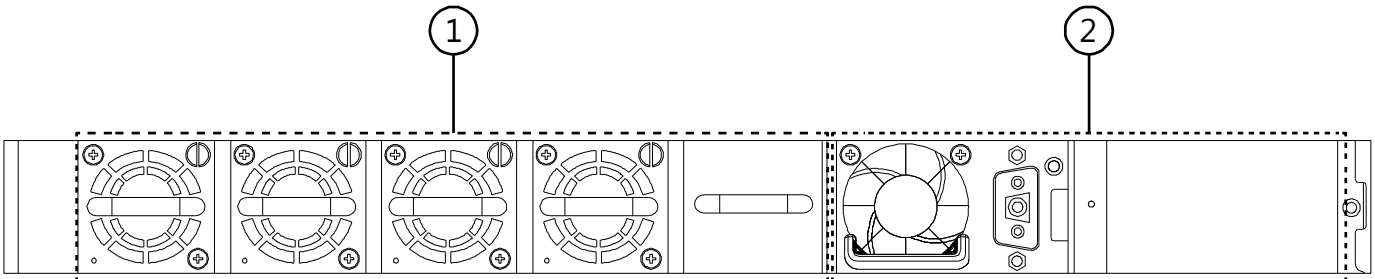

Figure 4-4 Back Panel of SNQ-60x0-320F Series Switch with DC Power Supply Module

The following table lists the slots and modules found on the back panel of the switch.

| Number | Component | Amount | Airflow | Description |
|--------|---------------------------|--------|-----------------------------------|--|
| 1 | Fan Module Slots | 5 | Front-to-Back OR Back-to-Front | There are 5 fan module slots on this switch. 4 fan modules are included. An additional fan module can be bought separately to improve airflow. |
| 2 | Power Supply Module Slots | 2 | Front-to-Back OR Back-to-Front | There are 2 power supply module slots on this switch. 1 power supply module is included (either AC or DC). An additional power supply module can be bought separately to improve redundancy. |



Note: For more information about fan module installation, refer to the **Installing Fan Modules into the Fan Module** section later on.



Note: For more information about power supply module installation, refer to the **Installing Power Modules into the Power Module Slots** and section later on.

Power Supply Modules

Switches in this series can either be AC powered or DC powered depending on the power supply modules used. After the initial purchase of a switch in this series, at least one power supply module will be included in the package. This power supply can either be one of the following:

AC Power Supply Modules

- **AC-0460W-12-FB:** AC Power Supply (Front-to-Back Airflow), 100 VAC to 240 VAC, 460 Watt.
- **AC-0460W-12-BF:** AC Power Supply (Back-to-Front Airflow), 100 VAC to 240 VAC, 460 Watt.

DC Power Supply Modules

- **DC-0800W-12-FB:** DC Power Supply (Front-to-Back Airflow), -40.5 VDC to -60 VDC.
- **DC-0800W-12-BF:** DC Power Supply (Back-to-Front Airflow), -40.5 VDC to -60 VDC.

In addition to the main power supply module, a secondary optional power supply module can be acquired and plugged into the second power supply module slot. The secondary power supply module will act as the backup for the primary power supply if the primary power connection fails. The switch from primary to secondary will take place immediately and automatically.



Note: An AC power supply module cannot be used together with a DC power supply module to provide redundancy. The primary and secondary power supplies must both be either AC supplied or DC supplied, depending on the power supply module inserted.

The power supply modules are hot-swappable, meaning, that they can be inserted and removed while the switch is powered on. This feature enhances the reliability of this switch. However, in the event that a power failure might occur in the environment and no UPS is used, as a precaution, unplug the power cord from the switch. After the return of power, you can plug the power cord back into the switch's power connector.



Note: Never leave an open power supply module slot open, without a cover panel, as this will negate the airflow within the switch.

Fan Modules

Switches in this series are powerful computing devices that require consistent airflow that is unobstructed. One of the well-thought design aspects of switches in this series is that airflow can be channeled either from the front of the switch to the back of the switch (**front-to-back airflow**) or from the back of the switch to the front of the switch (**back-to-front airflow**). When airflow is properly channeled, the internal temperature of the switch will remain in the safe zone, improving the reliability of the components used in the switch.



Warning: As a precaution, install the switch in a fairly cool and dry place within the acceptable temperature and humidity operating ranges.

After the initial purchase of a switch in this series, at least 4 fan modules will be included in the package. These fan modules must support the **same airflow direction** and can either be one of the following:

Fan Modules

- **FAN-17000-FB:** Fan Module (Front-to-Back Airflow).
- **FAN-17000-BF:** Fan Module (Back-to-Front Airflow).

In addition to the 4 main fan modules, an optional 5th fan module can be acquired and plugged into the 5th fan module slot.

The fan modules are also hot-swappable, meaning, that they can be inserted and removed while the switch is powered on. This feature enhances the reliability of this switch.



Note: The fan modules' airflow direction and the power supply modules' airflow direction must be identical to maximize air circulation through the switch.



Note: Never leave an open fan module slot open, without a cover panel, as this will negate the airflow within the switch.

Side Panel Components

The side panels of switches in this series feature 6 frontal rack-mount bracket screw holes and 10 rack-mount slider bracket pegs on each side. Frontal rack-mount brackets can be attached to the side panels, where screw holes are provided.

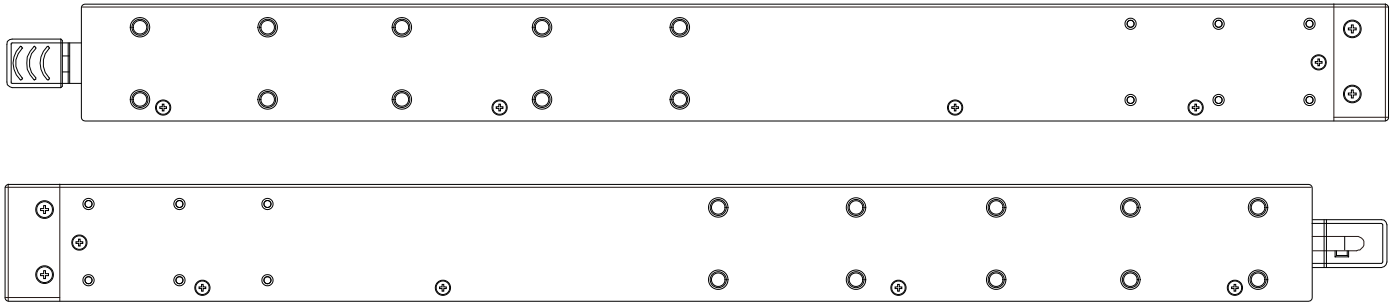

Figure 4-5 Side Panels of SNQ-60x0-320F Series Switch



Note: For more information about rack-mount installation, refer to the **Installation into a Rack** section later on.

Hardware Installation

Installation Guidelines

This section will discuss the hardware installation guidelines that administrators must follow in order to properly and safely install this switch into the appropriate environment.



Note: Please read through the **Safety Instructions** chapter before starting any installation discussed in this chapter.

Installation using the Rubber Feet

When installing the switch in an area other than inside a switch rack, like on a desktop, rubber feet can be attached to the bottom panel of the switch. On the bottom panel of the switch, there are clearly marked squares where the rubber feet can be attached. These marked squares are usually found close to the corners of the switch's bottom panel.

Adhesive material is included on the rubber feet. Simply pull away the protective sticker, of each rubber foot and then attach the foot into the appropriately marked square. The rubber feet cushion the switch, protecting the casing from scratches and preventing it from scratching other surfaces.

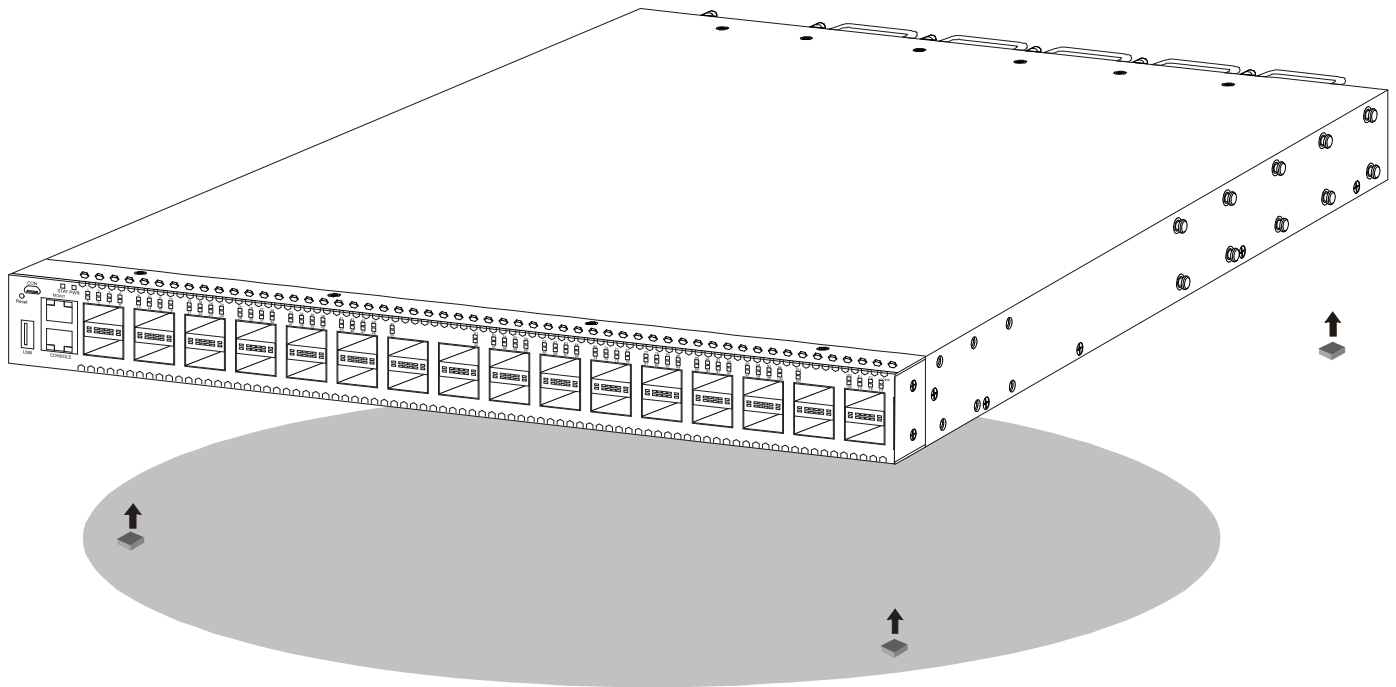

Figure 5-1 Installation using the rubber feet

Install the switch on a sturdy, level surface that can support the weight of the switch. Do not place any heavy objects on the switch. Make sure that there is proper heat dissipation from and adequate ventilation around the switch. Leave at least 10 cm (4 inches) of space at the front and rear of the switch for ventilation.

Installation into a Rack

Normally, ToR switches are installed not only into a rack-mount unit but at the top of the rack. The switch can be mounted in a standard 19"(1U) rack using the provided mounting brackets. The following section will explain how to install the rack-mount brackets onto the switch and then mount the switch into a standard 1U rack-mount unit.

The following parts will be used to install the switch into a rack-mount unit:

- One pair of frontal rack-mount brackets.
- One pair of rack-mount slider brackets.

- Eight Phillips-head frontal rack-mount bracket screws.

Additional equipment needed to install the switch into a rack-mount unit:

- One Phillips-head screwdriver. This screwdriver will be used for the rack-mount bracket screws
- One additional screwdriver. This screwdriver will be used for the rack-mount unit screws and its type and size depends on the rack-mount unit screws being used.
- Eight rack-mount unit screws. These screws will be used to attach the switch onto to the rack-mount unit and are not included in the switch’s packaging as rack-mount units differ at each installation site.

The figure below illustrates how to install the **frontal rack-mount brackets** onto the switch.

1. Place the switch on a flat horizontal surface.
2. Position the frontal rack-mount bracket over the screw holes on the side of the switch. The ears of the bracket must be facing forward and outwards.
3. Use the frontal rack-mount screws and the Phillips-head screwdriver to fasten the bracket onto the side of the switch.
4. Repeat steps 1 to 3 for the other frontal rack-mount bracket on the other side of the switch.

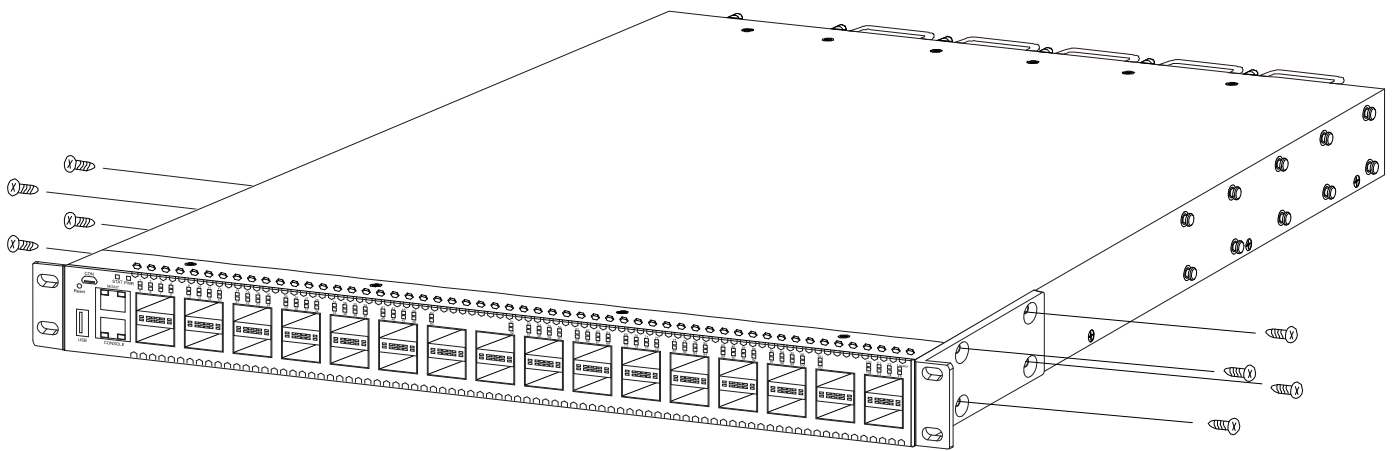

Figure 5-2 Attach frontal rack-mount brackets to switch

The figure below illustrates how to install the **rack-mount slider brackets** onto the rack-mount unit.

5. Take one rack-mount slider bracket and position it over the screw holes, on the back of the rack-mount unit, at the appropriate height. The ears of the bracket must be facing backwards and outwards.
6. Use the rack-mount unit screws and the additional screwdriver to fasten the bracket onto the back of the rack-mount unit.
7. Take the second rack-mount slider bracket and repeat steps 1 and 2, on the opposite side of the back of the rack-mount unit. Make sure to horizontally align the two rack-mount slider brackets.

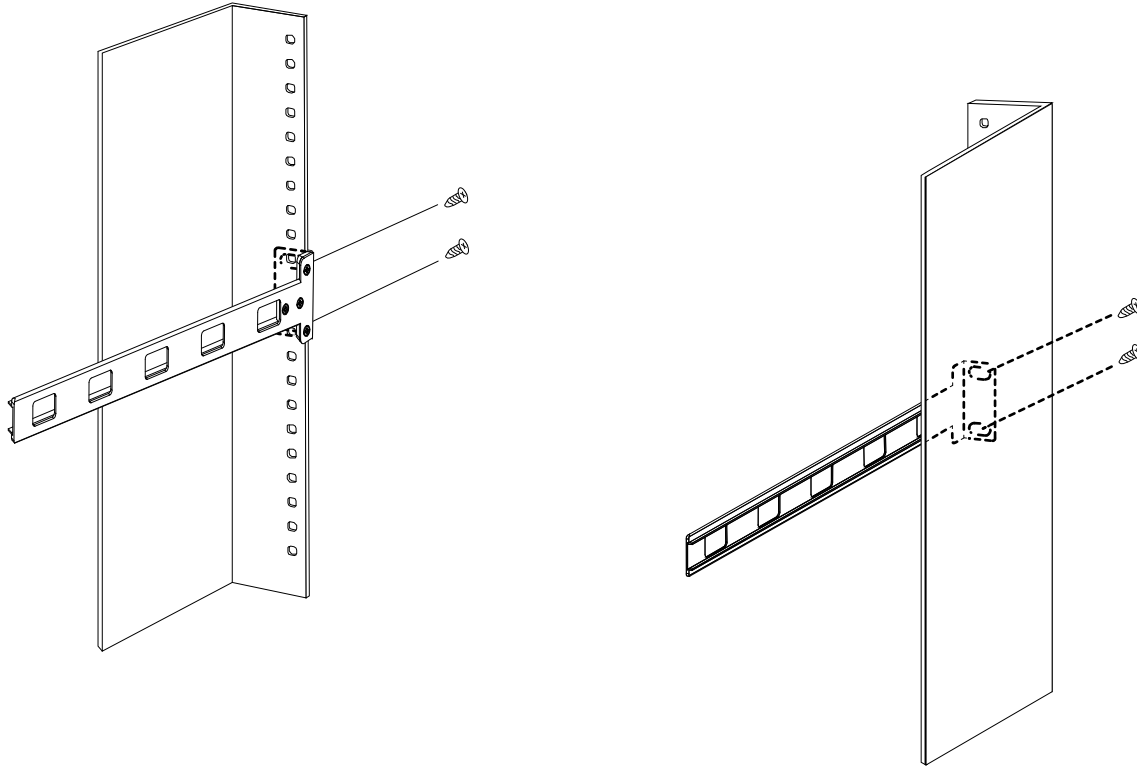

Figure 5-3 Attach rack-mount slider brackets to rack

The figure below illustrates how to mount the switch onto the **rack-mount slider brackets**.

8. Position the switch so that the rack-mount slider brackets align horizontally within the two rows of rack-mount slider bracket pegs found on the side panel of the switch.
9. Slide the switch carefully backwards so that the rack-mount slider brackets fit into the space between the two rows of rack-mount slider pegs.

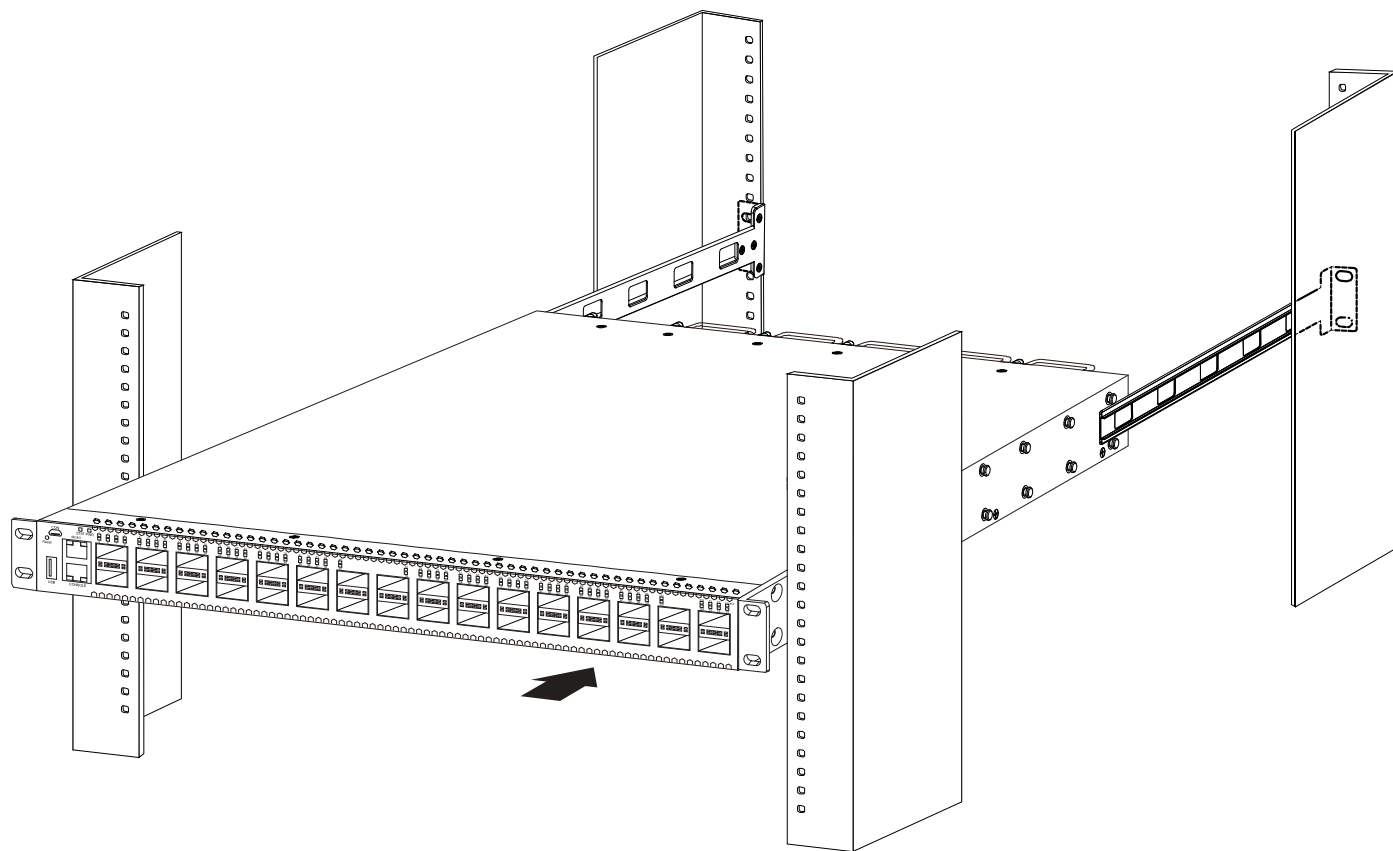

Figure 5-4 Slide switch into position

The figure below illustrates how to complete the rack-mount installation.

10. Use the rack-mount unit screws and the additional screwdriver to fasten the frontal rack-mount brackets onto the front of the rack-mount unit.

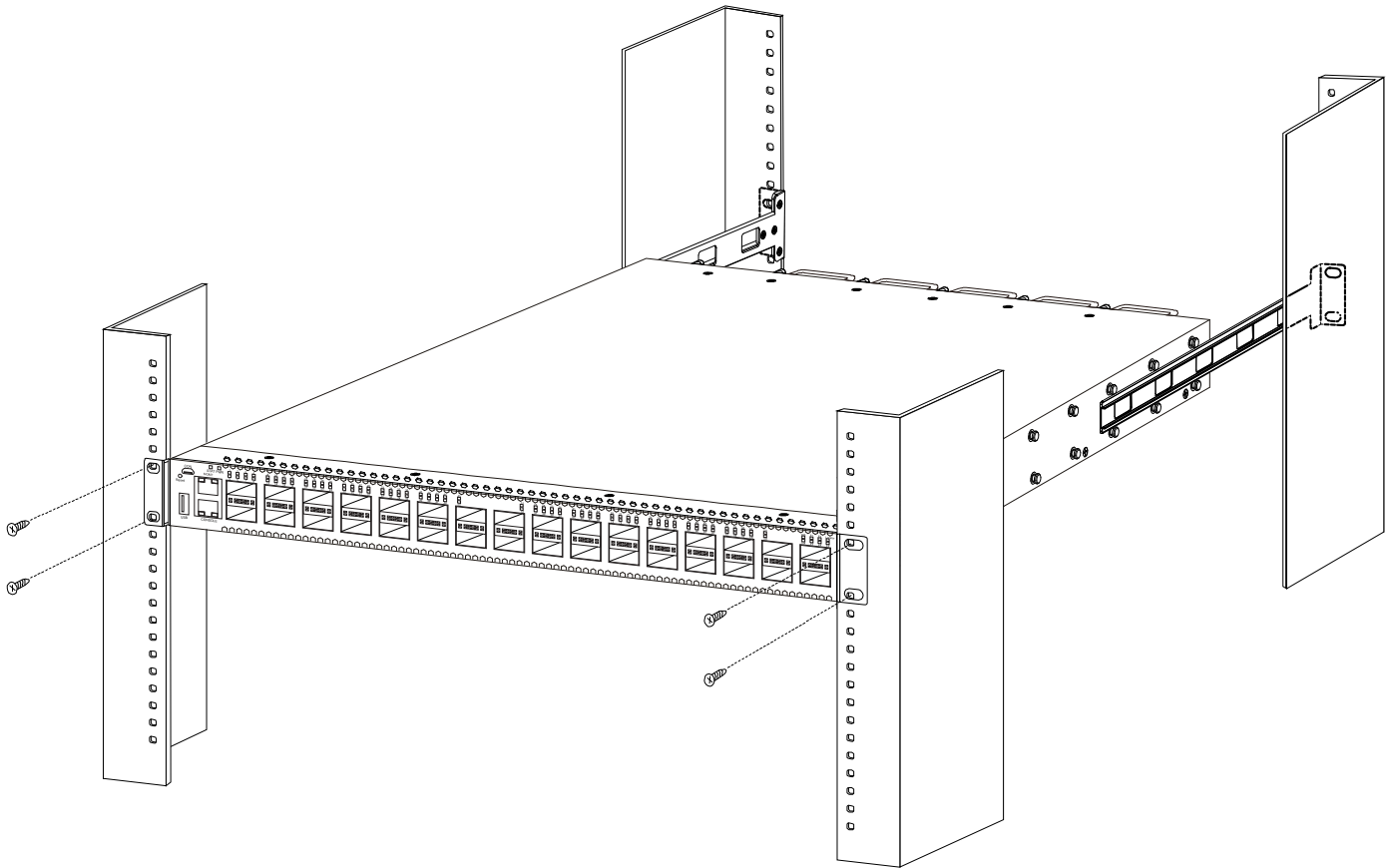

Figure 5-5 Fasten switch's front brackets to rack



Note: Make sure that there is adequate space around the switch to allow for proper air flow, ventilation, and cooling.

Installing Transceivers into the Transceiver Ports

Switches in this series have 32 QSFP+ ports. QSFP+ technology allows a smooth transition from 10 to 40 Gigabit Ethernet infrastructures in data centers. Each of the switch's QSFP+ ports can operate in either the native 40 Gigabit Ethernet mode or the 4 times 10 Gigabit Ethernet mode. This switch supports both fiber and copper cabling solutions for these two modes.

For low-cost cabling, copper-based 40 Gbps Twinaxial cables can be used, and for longer cable reaches, Short-Reach (SR) optical transceivers are excellent. Connectivity can be established from the QSFP+ ports to 10 Gigabit Ethernet switches or hosts using a splitter cable that has a QSFP+ transceiver on one end and four SFP+ transceivers on the other end. Similar capability can be achieved on the fiber solution by using QSFP+ SR4 transceivers on both ends and procuring third-party fiber splitter MPO-to-LC cables.

The figure below illustrates how to properly insert QSFP+ transceivers into the switch's QSFP+ ports.

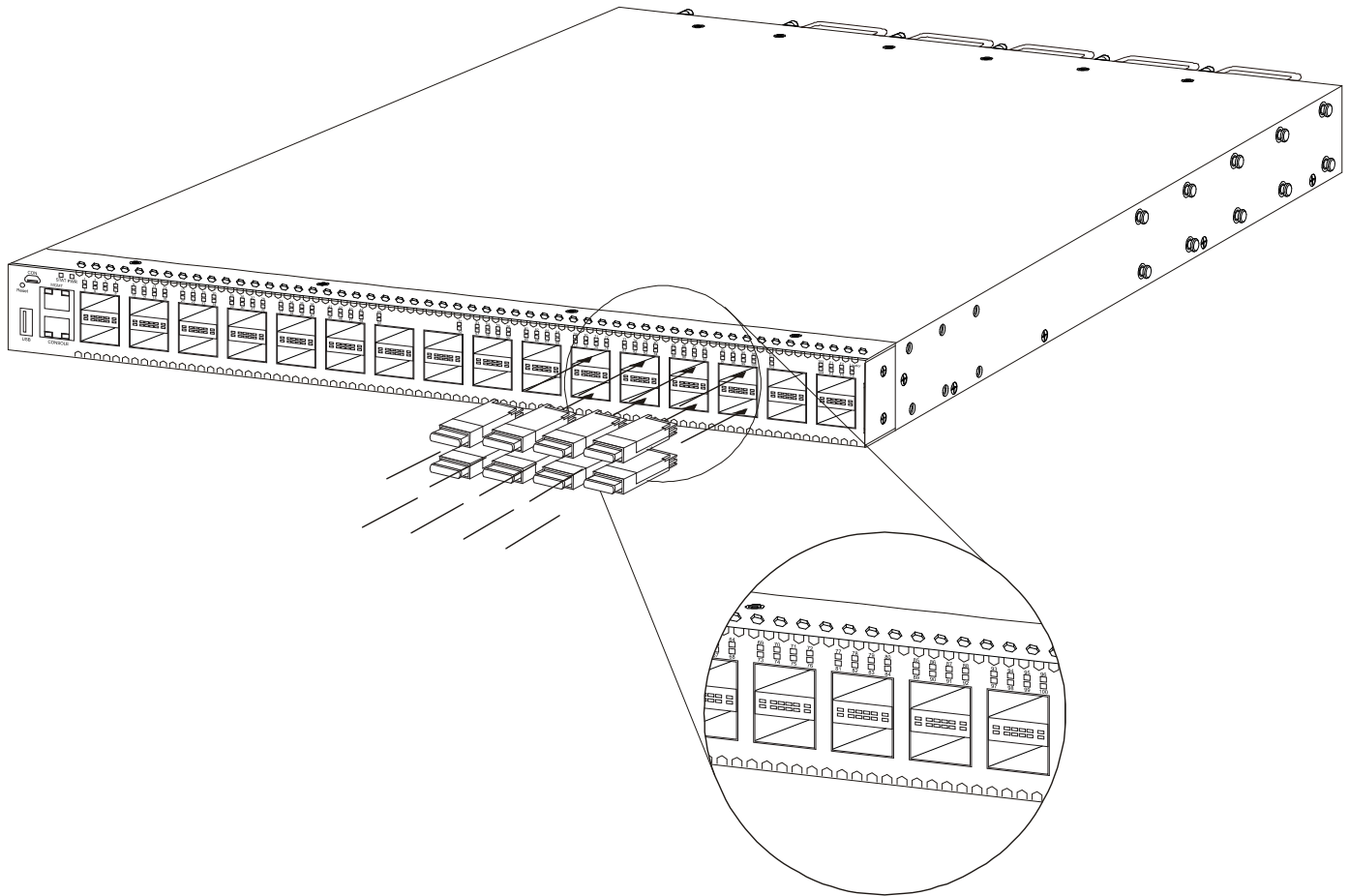

Figure 5-6 Installing Transceivers into the Transceiver Ports

The following table lists the QSFP+ transceiver types supported.

| Brand | Part Number | Transceiver | Speed | Cable | Distance |
|----------------|-----------------------|-------------|-------------|-----------------------------------|------------------|
| AVAGO | AFBR-79EQDZ | QSFP+ | 40 Gbps | Multi-mode Fiber (850 nm), SR4 | Up to 150 meters |
| TYCO | 2053638-1 | QSFP+ | 40 Gbps | Direct-Attached-Cable (Passive) | 1 meter |
| | 2053638-3 | QSFP+ | 40 Gbps | Direct-Attached-Cable (Passive) | 3 meters |
| | 2053638-5 | QSFP+ | 40 Gbps | Direct-Attached-Cable (Passive) | 5 meters |
| | 2053453-4 | QSFP+ | 4 x 10 Gbps | 1 QSFP+ to 4 SFP+ (Copper Cables) | 3 meters |
| | 2053453-6 | QSFP+ | 4 x 10 Gbps | 1 QSFP+ to 4 SFP+ (Copper Cables) | 5 meters |
| FOXCONN | 2GSPS0A-02G-EF | SFP+ | 10 Gbps | Direct-Attached-Cable (Passive) | 1 meter |
| | 2GSPS0B-02G-EF | SFP+ | 10 Gbps | Direct-Attached-Cable (Passive) | 3 meters |
| | 2GSPS8C-02G-EF | SFP+ | 10 Gbps | Direct-Attached-Cable (Passive) | 5 meters |
| | 2GSPGGA-18G-DF | QSFP+ | 40 Gbps | Direct-Attached-Cable (Passive) | 1 meter |
| | 2GSPGWX-19G-DF | QSFP+ | 40 Gbps | Direct-Attached-Cable (Passive) | 3 meters |

Installing Power Modules into the Power Module Slots

Switches in this series can have 2 redundant power supplies installed. When the one power supply fails, the second power supply will automatically take over the power supply responsibilities until the faulty power supply has been replaced.

Installing an AC Power Supply Module

This section will assist administrators with the installation and replacement of AC power supply modules in this switch. On the back panel of the switch, there are two power supply module slots.

The figure below illustrates how to properly install an AC power supply module.

1. It is important to make sure which **airflow direction** is used in this switch. Have a look at the fan modules installed and make sure that the AC power supply module supports the same airflow direction. The airflow direction can either be **front-to-back** or **back-to-front** airflow.
2. Remove the power supply module slot's protective cover by simply pulling the lever attached to it. The cover should come off without any difficulty.
3. Insert the AC power supply module, without an AC power cord supplying power, into the power supply module slot. Make sure that the AC power supply module is inserted all the way until the clip clicks into place.
4. Connect one end of the AC power cord, included in the package, into the grounded electrical outlet at the site and insert the other end of the AC power cord into the AC power port of the AC power supply module. The switch will automatically adjust the voltage supplied to the voltage needed as this power supply supports any voltage power supply in the range from 100VAC to 240VAC at 50Hz to 60Hz.

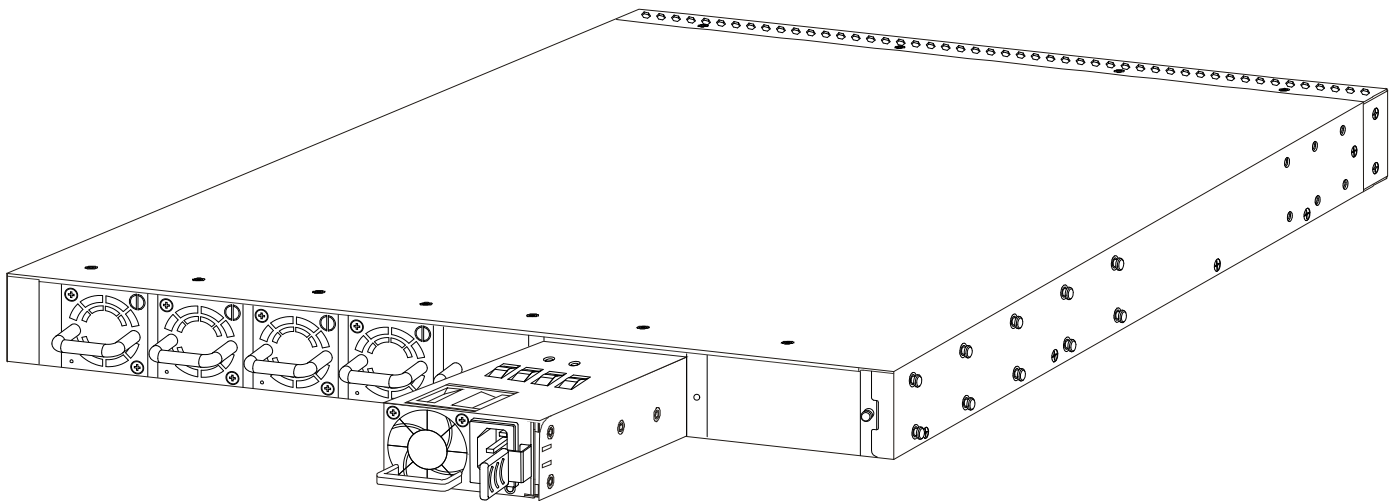

Figure 5-7 Installing an AC Power Supply Module (Before)



Note: By default, only one power supply module is installed in the second power supply module slot. The open power supply module slot will be covered with a panel. When purchasing a second power supply module, make sure that the airflow of the new power supply module functions in the same direction as the existing power supply module. Never leave an open power supply module slot open, without a cover panel, as this will negate the airflow within the switch.

The figure below illustrates how the back panel will look with an AC power supply module properly installed.

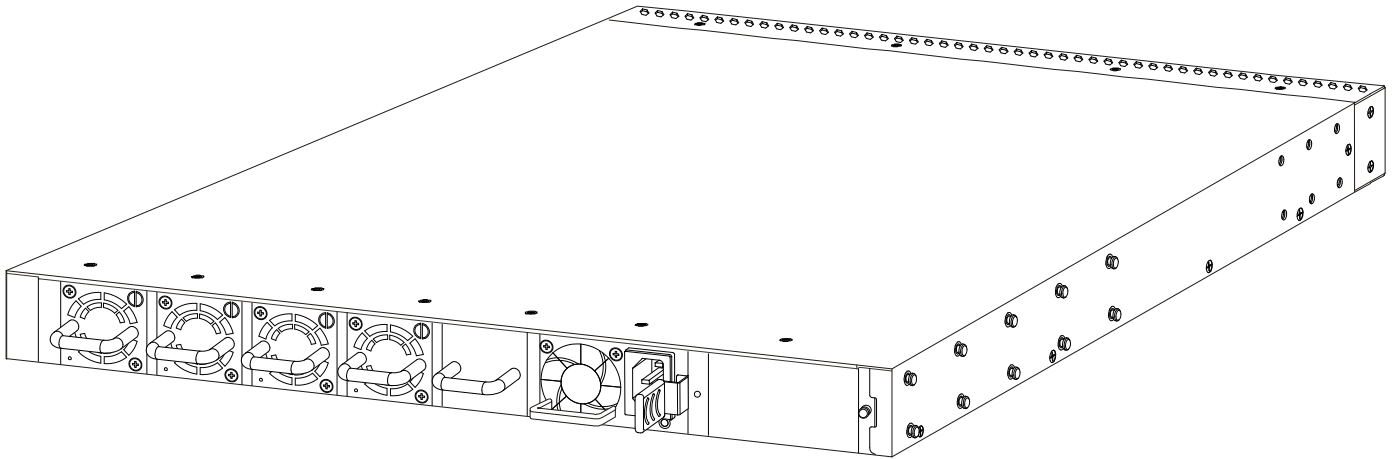

Figure 5-8 Installing an AC Power Supply Module (After)

To remove the AC power supply module, remove the AC power cord and then press the clip to the left and pull the lever backwards.

Installing a DC Power Supply Module

This section will assist administrators with the installation and replacement of DC power supply modules in this switch. On the back panel of the switch, there are two power supply module slots. The input DC voltage requirement for the DC power supply module is between **-40.5 VDC** to **-60 VDC**.

The figure below illustrates how to properly install a DC power supply module.

1. It is important to make sure which **airflow direction** is used in this switch. Have a look at the fan modules installed and make sure that the DC power supply module supports the same airflow direction. The airflow direction can either be **front-to-back** or **back-to-front** airflow.
2. Remove the power supply module slot's protective cover by simply pulling the lever attached to it. The cover should come off without any difficulty.
3. Insert the DC power supply module, without a DC power cord supplying power, into the power supply module slot. Make sure that the DC power supply module is inserted all the way until the clip clicks into place.
4. Connect one end of the DC power cord, included in the package, to a DC power source and insert the other end of the power cord to the DC power port connectors of the DC power supply module.



Warning: Make sure that the voltage requirement and connection polarity (positive and negative) is correct before connecting the power cord to the power port connectors of the power supply module to avoid any damage.

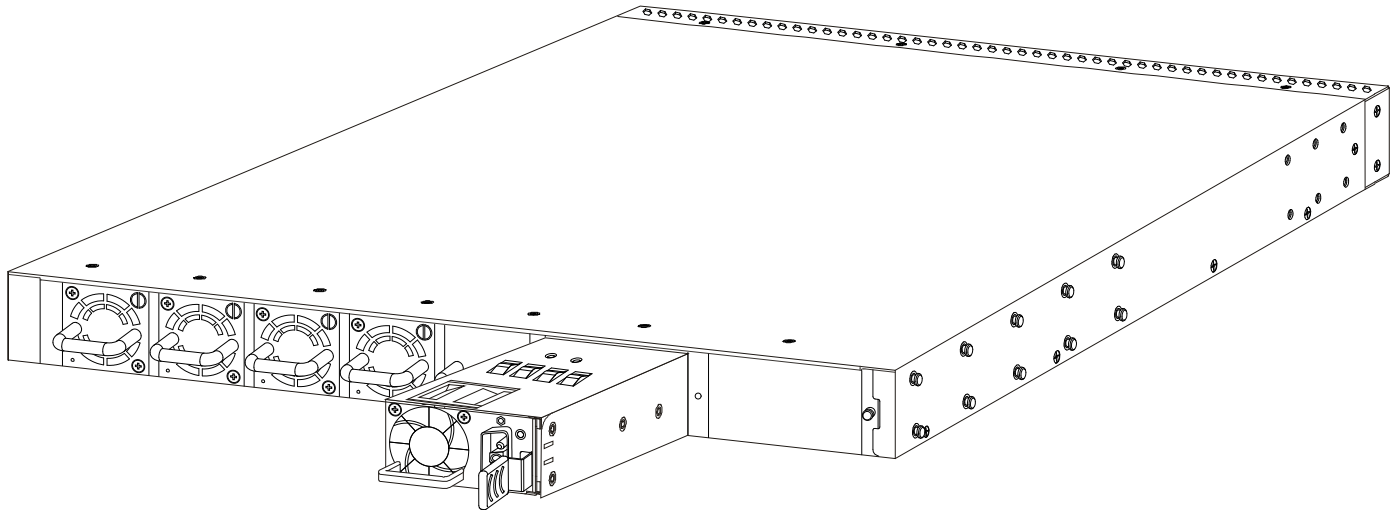

Figure 5-9 Installing a DC Power Supply Module (Before)

The figure below illustrates how the back panel will look with a DC power supply module properly installed.

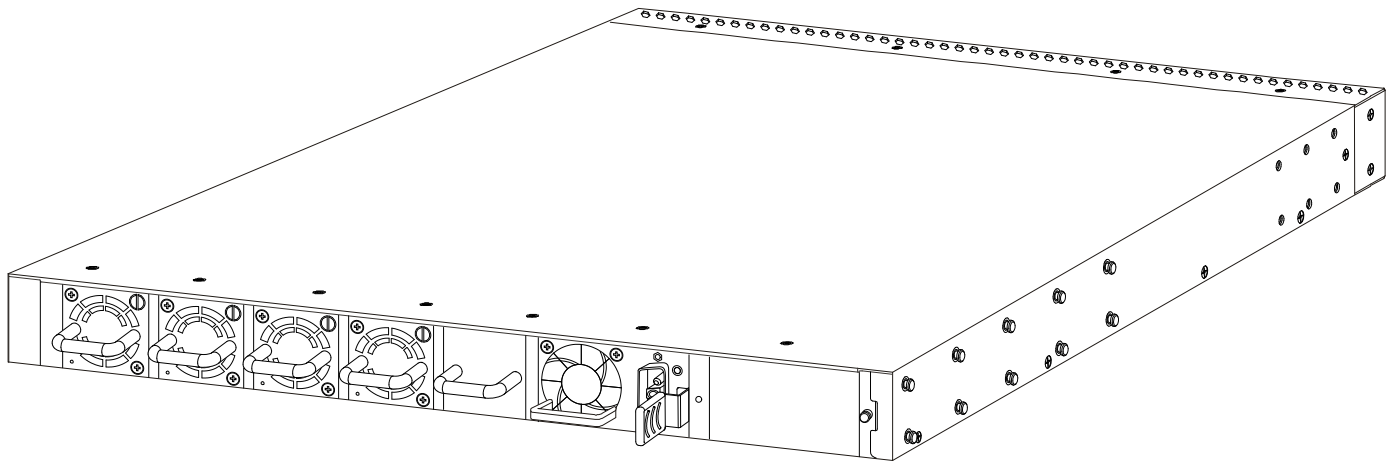

Figure 5-10 Installing a DC Power Supply Module (After)

When installing a DC power supply module, ground the chassis before connecting the switch to the DC power source. Use a minimum of 18 AWG stranded copper wire for grounding. The wire should be long enough to reach from the installed switch to the facility ground point.

To remove the DC power supply module, remove the DC power cord and then press the clip to the left and pull the lever backwards.

Installing Fan Modules into the Fan Module Slot

This section will assist administrators with the installation and replacement of fan modules in this switch. On the back panel of the switch, there are five fan module slots.

The figure below illustrates how to properly install a fan module.

1. It is important to make sure which **airflow direction** is used in this switch. Have a look at the power supply module(s) installed and make sure that the fan modules support the same airflow direction. The airflow direction can either be **front-to-back** or **back-to-front** airflow.
2. Remove the fan module slot's protective cover by simply pulling the lever attach to it. The cover should come off without any difficulty.
3. Insert the fan module into the fan module slot. Make sure that the fan module is inserted all the way until the clip clicks into place.

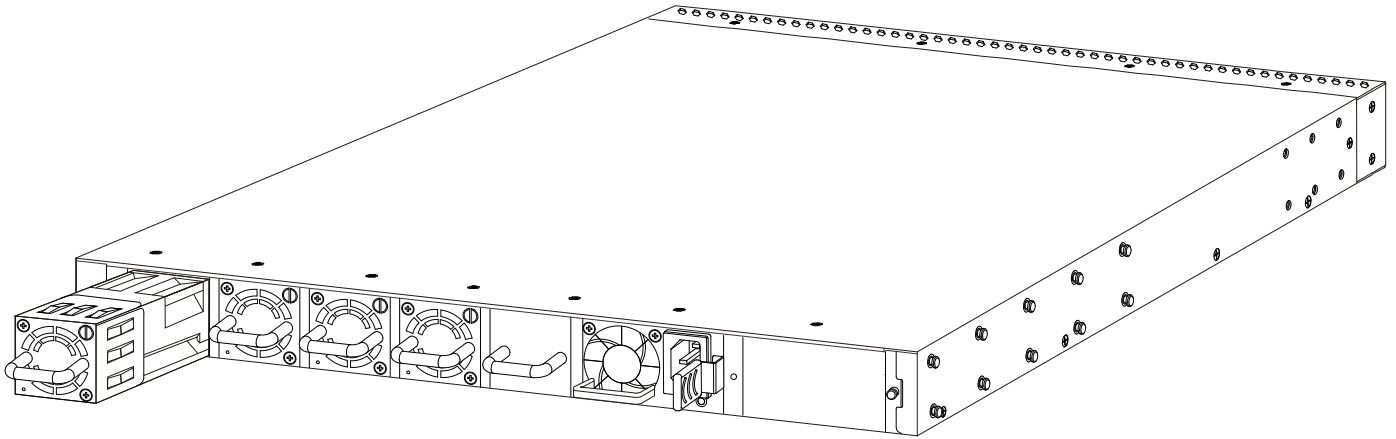

Figure 5-11 Installing Fan Module into the Fan Module Slot (Before)

The figure below illustrates how the back panel will look with 4 fan modules properly installed.

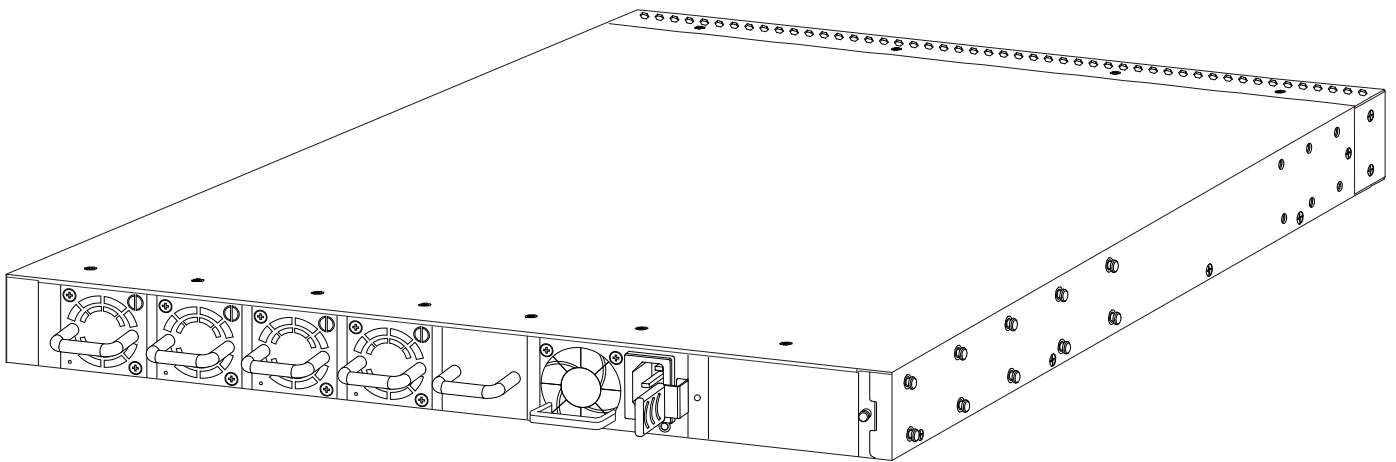

Figure 5-12 Installing Fan Module into the Fan Module Slot (After)

To remove the fan module pull the lever, in front of the fan of the fan module, backwards.

Technical Specifications

Product Specifications

The following tables list the product specifications for switches in this series.

| Category | Product Code | Description |
|----------|---------------|---------------|
| CPU | SNQ-6070-320F | Freescale CPU |
| | SNQ-60A0-320F | Intel CPU |

| Category | Specification | Description | |
|-----------------|----------------------------|------------------------------------|---|
| Physical | Form Factor | 1 RU Fixed Form Factor | |
| | Physical Ports | 32 QSFP+ ports (40 Gbps each) | |
| Performance | Switching Capacity | 2,560 Gbps | |
| | Forwarding Rate | 1,920 Mpps | |
| | Maximum Transmission Units | 12 Kbytes (Jumbo Frames) | |
| | Forwarding Mode | Store-and-Forward, Cut-and-Through | |
| Scalability | Buffer Size | 12 MB Shared | |
| | Number of MAC Addresses | 32,000 (Min), 288,000 (Max) | |
| | Routing Table | IPv4 | 16,000 (Min), 112,000 (Max) |
| | | IPv6 | 8,000 (Min), 56,000 (Max) |
| | Layer 2 Multicast | 16,000 | |
| | VLAN Entries | 4,000 | |
| | ACL Entries | 4,000 | |
| | Boot Flash Size | 8 MB | |
| Power | Number of Power Supplies | 2 (1 Included, 1 Excluded) | |
| | Types of Power Supplies | AC (Forward or Reversed Airflow) | |
| | | DC (Forward or Reversed Airflow) | |
| | Operating Power | SNQ-6070-320F | 239 Watts (32 QSFP+ ports with Twinax at 100% load) |
| | | | 272 Watts (32 QSFP+ ports with SR4 at 100% load) |
| | | SNQ-60A0-320F | 246 Watts (32 QSFP+ ports with Twinax at 100% load) |
| | | | 282 Watts (32 QSFP+ ports with SR4 at 100% load) |
| | Maximum Power | 456 Watts (from 460 Watt PSU) | |
| | AC Power Supply | Input Voltage | 100 VAC to 240 VAC (460 Watt) |
| | | Frequency | 50 Hz to 60 Hz |
| Efficiency | | 89% to 91% | |
| DC Power Supply | Input Voltage | -40.5 VDC to -60 VDC | |

| Category | Specification | Description |
|---------------------|------------------------------------|---|
| | | Efficiency 89% to 91% (at 220V) |
| | Typical Heat Dissipation | SNQ-6070-320F 817 BTU/hr (32 QSFP+ ports with Twinax at 100% load) |
| | | 929 BTU/hr (32 QSFP+ ports with SR4 at 100% load) |
| | | SNQ-60A0-320F 842 BTU/hr (32 QSFP+ ports with Twinax at 100% load) |
| | | 963 BTU/hr (32 QSFP+ ports with SR4 at 100% load) |
| | Maximum Heat Dissipation | 1,206 BTU/hr |
| Cooling | Number of Fan Modules | 5 (4 Included, 1 Excluded) |
| | Types of Fan Modules | Forward or Reversed Airflow |
| | Hot Swappable | Yes |
| | Fan Speeds | Programmable High and Low Speed |
| Noise Factor | All Fans at Low Speed | 59.50 dBA |
| | All Fans at High Speed | 76.10 dBA |
| Environment | Dimensions | 44mm (H) x 440mm (W) x 487.4mm (D) |
| | Weight | 9.29 kg (with 2 AC PSUs and 5 Fans installed) |
| | Operating Temperature | 0°C to 45°C (32°F to 113°F) |
| | Storage Temperature | -40°C to 70°C (-40°F to 158°F) |
| | Operating Relative Humidity | 0% to 95% (Non-condensing) |
| | Storage Relative Humidity | 0% to 95% (Non-condensing) |
| | Altitude | 0 to 3,000 meters (0 to 9,850 feet) |

Regulatory Standards Compliance

The following table lists the regulatory standards compliance for switches in this series.

| Specification | Description |
|------------------------------|---|
| Regulatory Compliance | Comply with CE Markings per directives 2004/108/EC and 2006/95/EC FCC/IC Report Class A BSMI UL/cUL Listed Mark CCC CB |
| Safety | IEC 60950-1 EN 60950-1 UL/CSA-C22.2 NO. 60950-1-07 CNS 14336-1 GB4943.1 |
| EMC | EN 55022/EN 55024, Class A |

| Specification | Description |
|----------------------|------------------------------|
| | FCC CFR47, Part 15B, Class A |
| | ICES-003, Class A |
| | CNS 13438, Class A |
| | GB9254 |
| | YDT993 |

Safety Instructions

The following sections provide safety precautions to follow when installing the switch.

Safety Precautions

For your protection, observe the following safety precautions when setting up your equipment:

- Follow all cautions and instructions marked on the equipment.
- Only trained and qualified personnel are allowed to install or to replace this equipment.
- Never push objects of any kind through openings in the equipment. Dangerous voltages may be present. Conductive foreign objects could produce a short circuit that could cause fire, electric shock, or damage to your equipment.
- This product is intended for restricted access whereby access is controlled through the use of a means of security (for example, key, lock, tool, badge access) and personnel authorized for access have been instructed on the reasons for the restrictions and any precautions that need to be taken.
- Remove all metal jewelry, such as rings and watches, before installing or removing a module from the device.
- Do not look directly at the fiber optic cable ends or inspect the cable ends with an optical lens.
- Do not install in direct sunlight, or a damp or dusty place.
- Do not expose the device to moisture or water.
- Disconnect all power supply cords before servicing.

Electrical Safety Precautions

For your protection, observe the following electrical safety precautions when setting up your equipment:

- Ensure that the voltage and frequency of your power source match the voltage and frequency inscribed on the equipment's electrical rating label.
- This switch is designed to work with power systems having a grounded neutral (grounded return for DC-powered products). To reduce the risk of electric shock, do not plug the switch into any other type of power system. Contact your facilities manager or a qualified electrician if you are not sure what type of power is supplied to your building.
- Not all power cords have the same current ratings. Do not use the power cord provided with your equipment for any other products or use. Household extension cords do not have overload protection and are not meant for use with these switches. Do not use household extension cords with this product.
- To prevent electric shock, do not remove the cover of this product. There are no user-serviceable parts inside. This unit contains hazardous voltages and should only be opened by a trained and qualified technician.
- Do not work on equipment or cables during periods of lightning activity.
- Check to see if there are any exposed copper strands coming from the installed wire. When this installation is done correctly there should be no exposed copper wire strands extending from the terminal block. Any exposed wiring can conduct harmful levels of electricity to persons touching the wires.
- The power source for the device should be located near the unit and should be easily accessible.
- Circuit Overloading: Consideration should be given to the connection of the equipment to the supply circuit and the effect that overloading of circuits might have on overcurrent protection and supply wiring. Appropriate consideration of equipment nameplate ratings should be used when addressing this concern.
- **Warning:** A readily accessible disconnect device shall be incorporated in the building installation wiring.
Attention: Un dispositif de déconnexion facilement accessible doit être incorporé dans l'installation électrique du bâtiment.
- **Caution:** Risk of explosion if battery is replaced by an incorrect type. Dispose of used batteries according to the instructions.
Attention: Risque d'explosion si la batterie est remplacée par un type incorrect. Jetez les piles usagées selon les instructions.
警告: 如果更換不正確之電池型式會有爆炸的風險 • 請依製造商說明書處理用過之電池 •

Rack-mount Safety Precautions

For your protection, observe the following rack-mount safety precautions when setting up your equipment:

- **Elevated Operating Ambient** - If installed in a closed or multi-unit rack assembly, the operating ambient temperature of the rack environment may be greater than room ambient. Therefore, consideration should be given to installing the equipment in an environment compatible with the maximum ambient temperature (T_{ma}) specified by the manufacturer.
- **Reduced Air Flow** - Installation of the equipment in a rack should be such that the amount of air flow required for safe operation of the equipment is not compromised.
- **Mechanical Loading** - Mounting of the equipment in the rack should be such that a hazardous condition is not achieved due to uneven mechanical loading.
- **Circuit Overloading** - Consideration should be given to the connection of the equipment to the supply circuit and the effect that overloading of the circuits might have on overcurrent protection and supply wiring. Appropriate consideration of equipment nameplate ratings should be used when addressing this concern.
- **Reliable Earthing** - Reliable earthing of rack-mounted equipment should be maintained. Particular attention should be given to supply connections other than direct connections to the branch circuit (for example, use of power strips).
- For safety, equipment should always be loaded from the bottom up. That is, install the equipment that will be mounted in the lowest part of the rack first, then the next higher systems, etc.
- To prevent the rack from tipping during equipment installation, the anti-tilt bar on the rack must be deployed.
- The mounting brackets provided must be used to securely mount the device in a rack-mount unit.

Ordering Information

Chassis

The following table provides the chassis ordering information for switches in this series.

| Part Number | Description | Parts Included |
|---------------------------|---|--|
| SNQ-6070-320F-AF-B | CPU: Freescale CPU. PSU: 1 x AC Power Supply (Front-to-Back Airflow) 460 Watt. Fan: 4 x Fan Modules (Front-to-Back Airflow). | 1 x AC-460W-12V-FB 4 x FAN-17000-FB |
| SNQ-6070-320F-AB-B | CPU: Freescale CPU. PSU: 1 x AC Power Supply (Back-to-Front Airflow) 460 Watt. Fan: 4 x Fan Modules (Back-to-Front Airflow). | 1 x AC-460W-12V-BF 4 x FAN-17000-BF |
| SNQ-6070-320F-DF-B | CPU: Freescale CPU. PSU: 1 x DC Power Supply (Front-to-Back Airflow) 800 Watt. Fan: 4 x Fan Modules (Front-to-Back Airflow). | 1 x DC-800W-12V-FB 4 x FAN-17000-FB |
| SNQ-6070-320F-DB-B | CPU: Freescale CPU. PSU: 1 x DC Power Supply (Back-to-Front Airflow) 800 Watt. Fan: 4 x Fan Modules (Back-to-Front Airflow). | 1 x DC-800W-12V-BF 4 x FAN-17000-BF |
| SNQ-60A0-320F-AF-B | CPU: Intel CPU. PSU: 1 x AC Power Supply (Front-to-Back Airflow) 460 Watt. Fan: 4 x Fan Modules (Front-to-Back Airflow). | 1 x AC-460W-12V-FB 4 x FAN-17000-FB |
| SNQ-60A0-320F-AB-B | CPU: Intel CPU. PSU: 1 x AC Power Supply (Back-to-Front Airflow) 460 Watt. Fan: 4 x Fan Modules (Back-to-Front Airflow). | 1 x AC-460W-12V-BF 4 x FAN-17000-BF |
| SNQ-60A0-320F-DF-B | CPU: Intel CPU. PSU: 1 x DC Power Supply (Front-to-Back Airflow) 800 Watt. Fan: 4 x Fan Modules (Front-to-Back Airflow). | 1 x DC-800W-12V-FB 4 x FAN-17000-FB |
| SNQ-60A0-320F-DB-B | CPU: Intel CPU. PSU: 1 x DC Power Supply (Back-to-Front Airflow) 800 Watt. Fan: 4 x Fan Modules (Back-to-Front Airflow). | 1 x DC-800W-12V-BF 4 x FAN-17000-BF |

Power Supply Modules

The following table provides the power supply module ordering information for switches in this series.

| Part Number | Description |
|-----------------------|--|
| AC-0460W-12-FB | AC Power Supply (Front-to-Back Airflow), 100VAC to 240VAC, 460 Watt. |
| AC-0460W-12-BF | AC Power Supply (Back-to-Front Airflow), 100VAC to 240VAC, 460 Watt. |
| DC-0800W-12-FB | DC Power Supply (Front-to-Back Airflow), -40.5 VDC to -60 VDC, 800 Watt. |
| DC-0800W-12-BF | DC Power Supply (Back-to-Front Airflow), -40.5 VDC to -60 VDC, 800 Watt. |

Fan Modules

The following table provides the fan module ordering information for switches in this series.

| Part Number | Description |
|---------------------|-------------------------------------|
| FAN-17000-FB | Fan Module (Front-to-Back Airflow). |
| FAN-17000-BF | Fan Module (Back-to-Front Airflow). |
